

**Subscriber Requirements**  
**for Computer to Computer Interface**  
**utilizing the NASDMS switch for**  
**the Trade Reporting and Compliance**  
**Engine system**  
**(TRACE<sup>SM</sup>)**

Version 1.~~2~~4

October 22, 2001

TABLE OF CONTENTS

1.0 TRACE CTCI INTERFACE .....	3
1.1 Introduction.....	3
1.2 Document Format.....	5
2.0 INPUT MESSAGE FORMATS.....	6
2.1 Header.....	6
2.2 Trailer.....	7
2.3 TRACE Transaction Text.....	<del>87</del>
2.4 Text Field Definitions.....	8
2.5 TRACE Message Types by Function.....	13
3.0 TRADE REPORTING INPUT MESSAGES.....	14
3.1 RP Trade Entry.....	14
3.2 Cancel Trade.....	16
3.3 No/Was Trade Entry.....	17
3.3.1 No Portion .....	17
3.3.2 Was Portion .....	17
4.0 SWITCH OUTPUT MESSAGES .....	19
4.1 TRACE Application Output Messages.....	19
4.2 Reject Message Format.....	19
4.3 TRACE UM Notification Message.....	20
4.4 Message Format Definitions.....	22
5.0 TRADE REPORTING OUTPUT MESSAGES.....	23
5.1 Acknowledgment Message (BCEN).....	23
5.1.1 TRACE Trade Entry Acknowledgment Message (BCEN).....	23
5.2 Allege Messages (BCAL) .....	26
5.2.1 TRACE Trade Entry Allege Message (BCAL) .....	26
5.3 Cancel Trade Acknowledgment (BCAN).....	29
5.4 No/Was TRACE UM Notification (BCNW).....	30
APPENDIX A --- TCP/IP Connection NASDAQ CTCI TCP/IP Client Interface Specification .....	<del>3436</del>
Purpose .....	<del>3436</del>
Organization .....	<del>3436</del>
Setup.....	<del>3436</del>
Testing.....	<del>3537</del>
Establishing a TCP/IP Connection.....	<del>3537</del>
CTCI TCP/IP Message Format .....	<del>3840</del>
CTCI TCP/IP Session Management.....	<del>3941</del>
Control Messages .....	<del>4042</del>
Logon and Logon Response .....	<del>4042</del>
Heartbeat Query and Response.....	<del>4244</del>
Flow Control .....	<del>4446</del>
Logical Channel State Query and Response .....	<del>4648</del>
Sending a CTCI Message .....	<del>4850</del>
Receiving a CTCI Message.....	<del>4850</del>
CTCI Message Sequence Verification.....	<del>4850</del>
APPENDIX B --- CTCI Rejection Messages.....	<del>4951</del>

## **CONFIDENTIAL**

This specification is being forwarded to you strictly for informational purposes. It is solely for the purpose of developing or operating systems for your use that interact with systems of The Nasdaq Stock Market, Inc. (*Nasdaq*) and its affiliates (collectively, the *Corporations*). This specification is proprietary to Nasdaq. Nasdaq reserves the right to withdraw, modify, or replace the specification at any time, without notice. No obligation is made by Nasdaq regarding the level, scope, or timing of Nasdaq's implementation of the functions or features discussed in this specification. THE SPECIFICATION IS "AS IS", "WITH ALL FAULTS" AND NASDAQ MAKES NO WARRANTIES, AND DISCLAIMS ALL WARRANTIES, EXPRESSED, IMPLIED, OR STATUTORY RELATED TO THE SPECIFICATIONS. THE CORPORATIONS ARE NOT LIABLE FOR ANY INCOMPLETENESS OR INACCURACIES. THE CORPORATIONS ARE NOT LIABLE FOR ANY CONSEQUENTIAL, INCIDENTAL, OR INDIRECT DAMAGES RELATING TO THE SPECIFICATIONS OR THEIR USE. It is further agreed by you by using this specification, that you agree not to copy, reproduce, or permit access to the information contained in, the specification except to those with a need-to-know for the purpose noted above. Copyright 2001, The Nasdaq Stock Market, Inc., as an unpublished work. All Rights Reserved.

# 1.0 TRACE CTCI INTERFACE

---

## 1.1 Introduction

The TRACE System (TRACE) is a service of the Nasdaq Stock Market that performs two major functions: on-line trade reporting and dissemination.

Members will be provided with the capability of transmitting and receiving transaction information through the use of a Computer to Computer Interface (CTCI) linkage. This document describes the format of the message text to be used to interface through the NASDMS Switch to the TRACE application. For more information regarding the Nasdaq Message Switch, refer to the document titled, Subscriber Requirements for Using The Nasdaq Computer to Computer Interface for CAES, NNMS, SOES, SelectNet, ACES Passthru and the Primex Auction System, which can be found at the following link: <http://www.nasdaqtrader.com/trader/tradingservices/specsinstallguides/execctcispec.pdf>.

Participation in the TRACE system is mandatory for all NASD firms. CTCI participants are expected to build and update a TRACE image file of their own trades in their interface systems by using the TRACE input and output messages. Participants will be able to enter and correct TRACE trades through their CTCI interfaces during the TRACE reconciliation cycle that consists of T-day (original trade entries) and T+1 to T + n day entries (As-of trade entries up to one year). CTCI Participants may request retransmission of any trade or group of trades to update their TRACE image files during the permissible hours by calling Nasdaq Market Operations.

The Eastern Time operating hours of the TRACE system are as follows:

Market/System open :	8:00 A.M.
Market Close:	5:15 P.M.
System Close:	6:30 P.M.

For Media dissemination purposes, all trades executed and reported between 12:00:00 A.M. that day and before 5:15:00 P.M. will be considered for last sale/high/low calculations. Any trades executed before 5:15 P.M. but reported after that time will not affect any of the market aggregates. Trades executed between 5:15:01 and 06:30:00 will have the .A modifier attached. All trades executed between 06:30:01 and 11:59:59 p.m. must be reported the next business day As-Of.

When a trade is entered into TRACE, a control number will be assigned to identify the trade throughout its TRACE processing and a status will be assigned to reflect its processing state. As trades are entered into the system, TRACE will validate trade information, forward proper acknowledgment messages to the Reporting Parties (RP) and Allege messages to the Contra Parties (CP) of the trades. Acknowledgment and Allege messages will contain the terms of the trade, the TRACE assigned status and control number which uniquely identifies each trade. These messages will enable the TRACE CTCI participants to build their own TRACE image files. CTCI participants will utilize the TRACE assigned control numbers to communicate with the TRACE system for subsequent trade report correction processing. It is important to note that TRACE is a one-day system, i.e., trades entered on any specific day will be not be retained in the system after system close. Therefore any subsequent correction processes (Cancel or No/Was) will only be accepted on the same day the original trade was entered. A deletion of a previously reported trade submitted on a prior day is allowed via submission of a Reversal. Please see section 2.4 for details concerning the submission of a Reversal.

TRACE will forward proper Notification messages to the trading parties as trades are corrected. Each Notification message will contain the control number and the updated status of the corrected trade such that the trading parties will be able to update their TRACE image files.

Similarly, TRACE will forward copies of all messages to respective clearing firms for trades pertaining to their correspondents if they are chosen. However, clearing firms can only perform trade reporting on behalf of their correspondents through a TRACE Give-up arrangement.

The above message flow and TRACE image file techniques are applicable to CTCI environments only. A web participant, however, will operate from the Nasdaq TRACE file and will not receive all of the above messages.

The TRACE CTCI specifications are applicable to both the T-day and As-of (T+1 to T+n) trade reporting process. T-day original trade entries will be processed for trade reporting and dissemination. Any trade executed during or off market hours, which has not been reported during T-day, may be reported to TRACE on T+1 or later (up to one year) on an As-of basis.

A retransmission of TRACE messages may be requested by phone on a current day basis. The following information must be provided as part of the request:

TRACE Day -	TRACE (T-day or T+1 to T+n day) messages.
Message Type -	Specify if only one type (e.g. BCEN). If multiple message types, then all types will be retransmitted.
Start Time -	Start (original send) time for the messages to be retransmitted.
End Time -	End time for the messages to be transmitted.
Possible Dupe -	Specify if possible duplicates are to be included.
Address -	Specify if the retransmission is to be directed to an address other than the regular one(s) (the CTCI I1I2 specified in the TRACE Firm profile) for these messages. Note: A specified address may not be for a printer.

Note: This facility retransmits the requested messages in their original form. However, when retransmitted, their sequence numbers assigned by the message switch will be current, i.e. not a repeat of their originally transmitted numbers.

**Special Note for Current FIPS CTCI Participants**

Nasdaq no longer supports the X.25 protocol for CTCI connectivity. If your firm currently uses X.25 for FIPS CTCI, please call Judy Schwarz at (203) 385-4675 or Beverly Hinds-Brown at (203) 385-4502 for important information on migrating from FIPS to TRACE CTCI connectivity.

## **1.2 Document Format**

This document has been prepared to facilitate your development of an interface to the TRACE System. The sections have been divided to easily identify those messages that will be supported.

Section 1 describes the project and its purpose.

Section 2 defines the header and trailer that will be used for all input messages. It also defines all the fields used in TRACE.

Section 3 defines the input messages supported for Trade Reporting.

Section 4 describes general information for output messages generated by TRACE.

Section 5 describes the output message formats generated by TRACE.

## 2.0 INPUT MESSAGE FORMATS

Each TRACE input message format requires the same message "envelope" which is composed of three parts:

- I. Header - defines the beginning of the message, origin and destination of the message.
- I. Text - data included are TRACE entries which can be a Trade Entry, Cancel or No/Was.
- III. Trailer - defines the end of the message, date/time of the message, control sequence number.

The header and trailer formats of each type of input message are identical and will apply to every input message. The text of each input message varies and will be identified by a function code.

The following notes apply to all of the message formats:

- Note 1:** Required fields must be entered, unless otherwise noted.
- Note 2:** If a field is entered and the field is designated as an alphabetic field, only A-Z can be entered unless otherwise noted. If the field is designated as numeric, only 0-9 can be entered unless otherwise noted. Embedded spaces cannot be entered in alphabetic or numeric fields unless otherwise noted.
- Note 3:** At the end of each line, a line delimiter is required even if no data has been entered on the line. Where the line delimiter has been specified as CR LF (carriage return, line feed) the use of CR is optional. The LF, however must be entered.
- Note 4:** The maximum limit of 1024 characters per message block includes the Header and Trailer.
- Note 5:** Records reported in TRACE cannot be intermixed with messages pertaining to other Nasdaq systems (i.e., ACT, SOES, CAE, FIPS, etc.) in the same block.

### 2.1 Header

#### Line 0

**Entry Originator -** One to six character Entry Originator ID. This field is optional for firms that are not acting as a service bureau. For firms acting as a service bureau, this field is mandatory and must contain the four character MPID (as specified by the NASD) of the firm acting as the Reporting Party, (i.e., the firm entering the Trade Entry, Cancel or No/Was).

**CR LF -** Required line delimiter- carriage return, line feed.

#### Line 1

**Branch Office** 1-8 character alphanumeric (A-Z, a-z, 0-9, embedded spaces, left justified )

**CR LF -** Required line delimiter.

Line 1A

<b>Category -</b>	This field identifies the message category. Contains the constant "Other BACT" for TRACE.
<b>Space -</b>	Required field separator.
<b>Destination -</b>	A required field. Destination Code will be "BACT" for <b>all Trade Entry and No/Was transaction messages.</b> "BCER" will be used for Cancels. The destination Code will route CTCI transactions to TRACE for processing.
	<b>Note: Wrong assignment of Destination Code will result in a " Invalid Format" reject.</b>
<b>CR, LF, LF -</b>	Required line delimiter

## **2.2 Trailer**

The sequence number entered by the user will be validated by the Switch to determine if there is a number gap or if the number is equal to or less than a previously received number.

Each station on a service bureau line shall have an individual sequence check. As an example, the first entry for station 1 shall have a sequence number of 0001. Similarly, the first entry from station 2 shall also have a sequence number 0001.

The sequence number provided by the subscriber can be in one of the following formats:

- I. The sequence number immediately precedes the end-of-text code (interposed line feeds are disregarded) and is either: fixed at four digits, right justified, zero filled.  
Example: 0034  
or one to four digits preceded by a "dash"  
Example: -34.
- II. The sequence number may appear anywhere on the last line if it is immediately preceded by the letters "OL" (and an optional space).  
Example: OL 23 or OL23  
A third contiguous alphabetic character is optional.  
Example: O LX 23 or O LX23  
Fill zeros for high-order digits (e.g., OL 0023) are also optional.
- III. The sequence number may be one to four digits at the beginning of the line, if it is preceded by a line feed character or a space and followed by a space and non-numeric character.  
Example: 125 AXD  
The remainder of the field may also be used to include user identifiers such as date/time group.  
Example: 0012 /120179011  
The ETX character will immediately follow any of the above described sequence number formats.



## 2.3 TRACE Transaction Text

### Trade Entry

#### (Function U)

All original trades will be entered into the TRACE System. A Reporting Party (RP) Trade Entry will be processed for trade reporting. **This Function should also be used for submission of Reversals.**

### Cancel Entry

#### (Function C)

The RP reports a Cancel entry for a previously entered trade which was reported but for whatever reason decides to cancel. All T date trades can be canceled.

### No/Was Entry

#### (Function N)

The RP reports a No/Was correction to a previously entered trade which was reported today but was incorrect. The No/Was is applicable to all RP original entries on the date of entry. Please note a Reversal and a new As-Of trade must be submitted in lieu of No/Was when entries are T+1 or older.

## 2.4 Text Field Definitions

The following contains the general definitions for all fields that are contained within the TRACE Transaction text. Any specific information that is relevant to a particular transaction type can be found in the description of the transaction. In addition, these definitions apply to both TRACE Input transactions and TRACE Output messages.

<b>Function</b>		This field is required. Valid values are: U = Trade Entry C = Cancel Entry N = No/Was Entry
<b>As-of</b>		This field is used to denote whether the trade is an As-Of trade entry. Valid values are: Blank - T-Day trade Y - As-of T+1 to T+n Trade
<b>B/S Indicator</b>		A required one alpha character which shall equal one of the following: B - reporting firm (i.e., RP) bought S - reporting firm sold
<b>Reference Number</b>		A twenty character field, left justified, fill unused positions with spaces. Optionally, the subscriber may assign this Reference Number as a unique identifier to each trade. The subscriber may change this Reference Number in subsequent transactions pertaining to the same trade (i.e., No/Was). The TRACE System <b>will not</b> validate this field. TRACE will always return the subscriber entered Reference Number in the acknowledgment message (i.e., BCEN) associated with the trade to the enterer and will space fill this field in the allege message

		(i.e., BCAL) to the contra party of the trade.																						
<b>Volume</b>		A required twelve digit numeric field, format 9(7)v9(5) right justified. Report the actual number of bonds traded. For any trade which is greater than 9,999,999.99999 bonds, the trade must be broken into multiple trades such that each trade will have volume smaller than or equal to 9,999,999.99999 bonds. A trade that is an odd lot, i.e. ½ of a bond, would be reported as a decimal, i.e. 000000050000.																						
<b>Symbol</b>		An optional fourteen alphanumeric character field, left justified. <b><u>The field becomes required if the user does not submit a CUSIP.</u></b> It will contain the four to seven character Security ID. Fill unused positions with spaces.																						
<b>Price</b>		A required field which indicates the reportable bond price of the trade and consists of a dollar amount in decimals. Price will be reported in a 9(4) v 9(6) format. The reported price will include the dealer markup or markdown, however, it will exclude the commission. When reporting when-issued bonds, the price is not required unless a yield is not provided.																						
<b>Yield Sign</b>		“ - “ Yield is Negative, Blank - Yield is Positive																						
<b>Yield</b>		A required field. It denotes the yield at which the transaction was effected. For when-issued bonds, Yield is not required <b>unless Price is not provided.</b> Format is 9(6) v 9(6). Yield must be entered at least to three decimal points.																						
<b>CUSIP</b>		An optional field nine digit alphanumeric code assigned to the security by the CUSIP Service Bureau. <b><u>The field becomes required if the user does not submit a NASD symbol.</u></b>																						
<b>Seller Commission</b>		An optional eight digit numeric field that captures the commission fee charged by the executing broker on the sell side. A “0” entry is valid. This amount is points per bond. Commission will be reported in a 9(2) v 9(6) format.																						
<b>Buyer Commission</b>		An optional eight digit numeric field that captures the commission fee charged by the executing broker on the buy side. A “0” entry is valid. This amount is points per bond. Commission will be reported in a 9(2) v 9(6) format.																						
<b>Trade Modifier</b>		<p>A three character field used to indicate that the trade was executed with special provisions. The field is left justified, space fill unused positions. Fill with all spaces if field is not used. The following table describes the modifiers that are applicable to TRACE and their entry format. Please note the (.A &amp; SLD) modifiers are <b><u>system generated.</u></b></p> <p>Entry modifiers:</p> <table border="1"> <thead> <tr> <th><u>Description</u></th> <th><u>Format</u></th> <th><u>Priority</u></th> </tr> </thead> <tbody> <tr> <td>Seller Option</td> <td>SNN (Note 2)</td> <td>2</td> </tr> <tr> <td>Cash Option</td> <td>C</td> <td>2</td> </tr> <tr> <td>Next Day Option</td> <td>ND</td> <td>2</td> </tr> <tr> <td>Weighted average</td> <td>W</td> <td>1</td> </tr> <tr> <td>Regular</td> <td>Space (Note 3)</td> <td></td> </tr> </tbody> </table> <p><u>System assigned modifiers:</u></p> <table border="1"> <tbody> <tr> <td>After Market Hrs execution</td> <td>A (Note 1)</td> </tr> <tr> <td>Out of Sequence or Late</td> <td>SLD (Note 3)</td> </tr> </tbody> </table> <p>Note 1:</p>	<u>Description</u>	<u>Format</u>	<u>Priority</u>	Seller Option	SNN (Note 2)	2	Cash Option	C	2	Next Day Option	ND	2	Weighted average	W	1	Regular	Space (Note 3)		After Market Hrs execution	A (Note 1)	Out of Sequence or Late	SLD (Note 3)
<u>Description</u>	<u>Format</u>	<u>Priority</u>																						
Seller Option	SNN (Note 2)	2																						
Cash Option	C	2																						
Next Day Option	ND	2																						
Weighted average	W	1																						
Regular	Space (Note 3)																							
After Market Hrs execution	A (Note 1)																							
Out of Sequence or Late	SLD (Note 3)																							

		<p>The System will capture two trade modifiers. If there are trade modifiers along with system calculated time modifiers, the time modifiers will be displayed in the append modifier field (mentioned below). For a trade which was entered within the .A Time (i.e., 5:15pm (or Market Close) to 6:30 p.m.) the ".A" modifier will be assigned. However, If the user has already entered a trade modifier and the trade report time is late and also a .A trade, then the .A modifier will be appended in the Append Modifier field. The .A modifier will take priority over the .SLD modifier. Off Hours trades that cannot be reported to TRACE before 6:30 P.M. on T-Day should be reported into TRACE on T+1 on a As-of basis.</p> <p>Note 2:</p> <p>For a Seller Option, NN denotes the number of days for delivery and must be within the range 02, 04 to 60.</p> <p>Note 3:</p> <p>When the trade is reported by the subscriber as a Regular trade (i.e., Modifier = Space), TRACE will calculate the time interval between the execution Time and the TRACE Acceptance Time. If this time interval is greater than the required report time, TRACE will append the SLD modifier and consider it as a late trade report.</p>
<b>Append Modifier</b>		<p>A second three character modifier which will be assigned by the system and either display a space, (.A) = After Market hours Execution, or (SLD) = for Out of Sequence or late trades. <b>This field will only be populated when the system calculates that a time modifier (.A, SLD) is required.</b> When this happens only the time modifiers (.A, SLD) will appear in the Append Modifier field. If the user has already entered a trade modifier and the trade report time is late and also a .A trade, then the .A modifier will be appended in the Append Modifier field. The .A modifier will take priority over the .SLD modifier.</p>
<b>Override</b>		<p>A one character field that is used by the originator to indicate that the entered price or yield is valid although it may fall outside the reasonability check made by the system. The alpha "O" character will be used to specify a price/yield override. The override should not be used on initial submission; only after a trade report has been rejected for having a price/yield that is considered out of range.</p>
<b>CPID</b>		<p>This is a required field. A four alpha character field denoting the MPID of the Contra Party to the trade. If the Contra party is a customer, "C" may be reported as a valid entry. Contra of "C" is only valid when the transaction is entered by the reporting party. However, NASD member firms cannot qualify each other as a customer.</p>
<b>CPGU</b>		<p>The four alpha character MPID of the Contra Party give up firm if this transaction is a give up trade for the Contra Party. This field shall be space filled if it is not a give up.</p>
<b>CP Clear Number</b>		<p>This field is optional. It is used to identify the clearing broker who will clear this trade for the Contra Party.</p> <ul style="list-style-type: none"> <li>• If a value is entered, TRACE will validate that it is a numeric</li> </ul>

		<p>value in the 9999 format.</p> <ul style="list-style-type: none"> <li>• If no value is entered, TRACE will look in the firm profile and use the value in the default clearing number field and capture it on the trade record. If no clearing number exists in the firm profile then the clearing number field in the trade record will be left blank.</li> <li>• TRACE will not validate whether the clearing number entered corresponds to a valid clearing firm.</li> </ul>
<b>RPID</b>		This is a required field. A four alpha character field denoting the MPID of the Reporting Party of the trade.
<b>RPGU</b>		The four alpha character MPID of the Reporting Party give up firm if this transaction is a give up trade for the Reporting Party. This field shall be space filled if it is not a give up.
<b>RP Clear Number</b>		<p>This field is an optional field. It is used to identify the clearing broker who will clear this trade for the Reporting Party.</p> <ul style="list-style-type: none"> <li>• If a value is entered, TRACE will validate that it is a numeric value in the 9999 format.</li> <li>• If no value is entered, TRACE will look in the firm profile and use the value in the default clearing number field and capture it on the trade record. If no clearing number exists in the firm profile then the clearing number field in the trade record will be left blank.</li> <li>• TRACE will not validate whether the clearing number entered corresponds to a valid clearing firm.</li> </ul>
<b>Seller PA</b>		A one character P/A Indicator field for the Sell-side. It denotes whether the Seller is acting as "P" for principal or "A" for agent for this trade.
<b>Buyer PA</b>		A one character P/A Indicator field for the Buy-side. It denotes whether the Buyer is acting as "P" for principal or "A" for agent for this trade.
<b>Special Price Indicator</b>		<p>This field may contain the following entries:</p> <p>Y= the transaction was intentionally executed at a price not related to the current market. Not to be used for things like long or short settlement or average price trades, rather it is to be used when trading specified.</p> <p>b= Transaction price not special.</p> <p>If this field is used, the Special Price Memo field must be used. "Y" must be entered in this field if text is entered into the Special Memo field.</p>
<b>Execution Time</b>		This is a required field. A field denoting the time of execution in military time (HHMMSS) format. For example, if the trade was executed at 2:03:02 p.m. the entry will be 140302. Please enter times in Eastern Time. <b>This is a required field for all transactions submitted into TRACE.</b>
<b>Special Price Memo</b>		A fifty character alphanumeric subscriber MEMO field. This field must be used when the Special Price Indicator has been selected to describe the reason why the trade was executed at a special price. Fill unused positions with spaces. This field may be displayed to the

		Contra party.
<b>Internal Memo</b>		An optional ten character alphanumeric memo field. Fill unused positions with spaces. This field is not displayed to the Contra party. If a Reversal is submitted, the TRACE Control Number of the trade being reversed <b>must</b> be entered in this field.
<b>Contra Branch Sequence</b>		An optional eight (8) alphanumeric character field, (A-Z, 0-9 embedded spaces, left justified, pad with trailing spaces), to indicate the firm's branch office.
<b>Trade Date</b>		The date that the trade was executed. For an As-of trade, the date must be T+1 or older. For a Reversal transaction, the date must also be T+1 or older. The date must be a valid business date not older than one year (365 days). The format is MMDDYYYY.
<b>Automatic Give Up Flag</b>		<p>"Y" or blank.</p> <p>Y = Indicates an automatic give-up transaction, where an introducing broker is reporting the trade on behalf of the Executing Broker. <b>Note: when the AGU Flag is set to "Y", the transaction must be entered from the Seller's point of view.</b></p> <p>Blank = Not an AGU transaction.</p>
<b>Reversal Indicator</b>		<p>The valid values for this field are "R" or blank.</p> <p>R = Indicates a Reversal of the original trade entry.</p> <p>Blank = Not a Reversal transaction.</p> <p>As TRACE only allows cancellations (Function C) of trade reported on the same day, a Reversal should be submitted in order to cancel a trade that was reported on a prior day. A Reversal of a trade should be identical to the original trade entry, i.e., all of the original trade entry details must be entered for a trade to be reversed.</p> <p>When a Reversal is submitted, the TRACE Control Number of the original trade report <b>must</b> be entered in the <u>Internal Memo</u> field.</p>

## **2.5 TRACE Message Types by Function**

TRACE output messages are sent to the Reporting and Contra Party firms as verification for each TRACE transaction. The following table shows the output messages sent to the Reporting and Contra Parties as categorized by Function. Included below this table is one detailing messages being sent to both the Executing Broker and the Clearing Broker firms.

	Reporting Party Message Received	Contra Party Message Received
Trade Entry	BCEN	BCAL
Cancel	BCAN	BCAN
No/Was	BCNW	BCNW

## 3.0 TRADE REPORTING INPUT MESSAGES

### 3.1 RP Trade Entry

The Reporting Party will use this message to enter an original T Date or an As-Of Trade Entry into the TRACE System. A trade reportable Trade Entry will be processed if it satisfies the trade report requirement.

The RP Trade Entry may generate the following output message flow:

- o Reject message  
If a TRACE Trade Entry is rejected for any reason, the current reject message containing the reject reason and the echo of the trade will be returned to the entering RP.
- o BCEN (refer to Section 5.1.1)  
If a TRACE Trade Entry is accepted, a BCEN Acknowledgment message containing the TRACE "T" for trade reporting status and Control Number, and the echo of the trade will be returned to the RP. The entering firm may use this message to build the initial trade record in its image file.
- o
- o BCAL (refer to Section 5.2.1)  
If a TRACE Trade Entry is accepted, a BCAL Allege message containing the same contents as the BCEN will be forwarded to the contra side of the trade. The contra may use this message to build the initial trade record in its image file.
- o

The following table displays the TRACE Seller Trade Entry message format.

**Exhibit 3.1 TRACE Trade Entry Message Format**  
**Two Part Message**

Field Name	Position	Format	Contents/Comments
<b>Line 1</b>			
Function	1-1	X(1)	U = RP Trade Entry
As-Of	2-2	X(1)	Y = As-Of (T+1 to T+n) b= Original (T Date Entry)
B/S Indicator	3-3	X(1)	B=Bought, S=Sold
Reference Number	4-23	X(20)	User assigned reference number, not validated by system.
Volume	24-35	9(12)	Report the actual number of bonds traded. Format 9(7) v 9(5)
Symbol	36-49	X(14)	Bond Symbol
CUSIP	50-58	X(9)	Bond CUSIP
Filler	59	X(1)	Reserved for Future Use
Price	60-69	X(10)	Numeric Field, Price at which bond traded. Format 9(4)V9(6)
Yield Sign	70	X(1)	“-“ Yield is negative
Yield	71-82	9(12)	Yield format 9(6) v 9(6)
Seller Commission	83-90	9(8)	Commission format 9(2)V9(6)
Buyer Commission	91-98	9(8)	Commission format 9(2)v9(6)
CR LF			Carriage Return, Line Feed
<b>Line 2</b>			
Trade Modifier	1-3	X(3)	SNN=Seller, C=Cash, ND=Next Day, W=Weighted Average, b=Regular
Price Override	4	X(1)	O=Override, b=No override
CPID	5-8	X(4)	MPID of the Contra Party. “C” for Customer may be entered by the Reporting party.
CPGU	9-12	X(4)	MPID of give up on the Contra side
CP Clear Number	13-16	9(4)	Contra Party’s clearing Number, b=Major clearing Number
RPID	17-20	X(4)	Required MPID of the Reporting Party
RPGU	21-24	X(4)	MPID of give up on the Reporting side
RP Clear Number	25-28	9(4)	Reporting Party clearing Number, b=Major clearing Number
Seller PA Indicator	29	X(1)	P or b=Principal, A=agent
Buyer PA Indicator	30	X(1)	P or b=Principal, A=agent
Filler	31-32	X(2)	Reserved for Future Use
Execution Time	33-38	9(6)	Execution Time in HHMMSS format.
Internal Memo	39-48	X(10)	User Memo (Will not be displayed to Contra party)
Special Price Indicator	49	X(1)	Y=Special Price, b= Not Special Price
Filler	50	X(1)	Reserved for Future Use
Special Price Memo	51-100	X(50)	User Memo (may be displayed to Contra party)
Contra Branch Sequence	101-108	X(8)	Optional field, eight (8) alphanumeric
As Of or Reversal Trade Date	109-116	9(8)	mmddyyy format; Must be entered for all as-of and reversal transactions
Reversal Indicator	117	X(1)	b=not a Reversal, R = Reversal
Automatic Giveup Flag	118	X(1)	Contains “Y” if Automatic Giveup; Blank otherwise (Note: AGU transactions must be entered from the Seller’s point of view.)



Field Name	Position	Format	Contents/Comments
Reserved Field	119-130	X(12)	Reserved Field
CR LF			Carriage Return, Line Feed

### **3.2 Cancel Trade**

Firms will use this message to cancel a TRACE trade entry which was previously reported. Cancellation of a previously disseminated trade report will cause the cancel transaction to be disseminated as well. TRACE will forward a BCAN message to both parties of the trade to advise them that the specified trade is updated to Cancel status. All canceled trades will be deleted at the end of the entry day. The Cancel function can only be used when a trade was submitted on the same day.

#### **EXHIBIT 3.2 CANCEL TRADE MESSAGE FORMAT**

Field Name	Position	Format	Contents/Comments
Function	1-1	X(1)	C=RP cancels its own trade which it entered previously
Reference Number	2-21	X(20)	User assigned Reference Number
Control Number	22-31	9(10)	Control Number associated with the trade to be canceled

### 3.3 No/Was Trade Entry

Firms will use this function to enter a No/Was (amendment) trade to the TRACE System. The No/Was trade is applicable to both T date and T+N As-Of trades. The As-Of field can be used in a No/Was trade for trades originally entered as an As-Of. TRACE will determine if the new transaction is disseminated. The No/Was function can only be used when a trade was submitted on the same day.

In addition to the required field format requirements, the entering of a No/Was trade must also meet the following requirements.

- A No/Was correction is applicable to both parties' Trade entry.
- Both the No and the Was portion must be submitted.
- The No and the Was portions are part of the same message text and are not separated by 'CR LF' (line delimiter).
- A change to a trade entry symbol or CUSIP, Contra MPID, Contra Give Up, or Contra clearing number may not be made via the No/Was Correction entry. In order to effect such a change, it must be made by entry of a Cancel of the original entry, followed by a new original entry with the correct data.

#### 3.3.1 No Portion

#### EXHIBIT 3.3 NO TRADE MESSAGE FORMAT

Field Name	Position	Format	Contents/Comments
Function	1-1	X(1)	N = TRACE NO/WAS Trade Entry
Reference Number	2-21	X(20)	User assigned Reference Number
Control Number	22-31	9(10)	Control Number associated with the original trade

The WAS portion of the No/Was trade immediately follows the NO portion without a 'CR LF' between the two parts.

#### 3.3.2 Was Portion

The specification for the Was portion of the No/Was trade is the same as the TRACE RP Trade Entry (refer to Section 3.1) except it does not include the "U" Function.

Note: All fields must be included, including those whose content is indicated as optional, (blank fields are to be space filled and unused positions are to be space or zero filled wherever applicable). The No/Was will be processed for trade reporting and disseminated to the vendors through BTDS if trade report eligible. The TRACE System will assign a new control number to the Was portion and it will be processed as an original RP Trade Entry.

**EXHIBIT 3.3 NO/WAS TRADE ENTRY**

**Two Part Message**

Field Name	Position	Format	Contents/Comments
<b>Line 1</b>			
Function	1-1	X(1)	N = NO/WAS Trade Entry
Reference Number	2-21	X(20)	User Assigned Reference Number of the No trade
Control Number	22-31	9(10)	Control Number of the No trade
As-of	32	X(1)	Y=As-of (T+1 to T+n); b=Original (T Day entry)
B/S Indicator	33	X(1)	B=Bought, S=Sold
Reference Number	34-53	X(20)	User assigned reference number
Volume	54-65	9(12)	Report the actual number of bonds traded. Format 9(7) v 9(5)
Symbol	66-79	X(14)	Bond symbol
CUSIP	80-88	X(9)	Bond CUSIP
Filler	89	X(1)	Reserved for Future Use
Price	90-99	9(10)	Dollar price format 9(4) v 9(6)
Yield Sign	100	X(1)	“-“ Yield is Negative, Blank - Yield is Positive
Yield	101-112	9(12)	The yield at which the transaction was effected. For when-issued bonds, Yield is not required <b>unless Price is not provided..</b> Format 9(6)v9(6)
Seller Commission	113-120	9(8)	Commission format 9(2) v 9(6)
Buyer Commission	121-128	9(8)	Commission format 9(2) v 9(6)
CR, LF			Carriage Return, Line Feed
<b>Line 2</b>			
Trade Modifier	1-3	X(3)	SNN=Seller, C=Cash, ND=Next Day, W=Weighted Average, b=Regular
Price Override	4	X(1)	O=Override, b=No override
CPID	5-8	X(4)	MPID of the Contra Party. “C” for Customer may be entered by the Reporting party.
CPGU	9-12	X(4)	MPID of give up on the Contra side
CP Clear Number	13-16	9(4)	Contra party clear Number, b=Major clear Number
RPID	17-20	X(4)	Required MPID of the Reporting Party
RPGU	21-24	X(4)	MPID of give up on the Reporting side
RP Clear Number	25-28	9(4)	Reporting Party clear Number, b=Major clear Number
Seller PA Ind.	29	X(1)	P or b=Principal, A=agent
Buyer PA Ind.	30	X(1)	P or b=Principal, A=agent
Filler	31-32	X(2)	Reserved for Future Use
Execution Time	33-38	9(6)	Execution Time in HHMMSS format.
Internal Memo	39-48	X(10)	User Memo (Will not be displayed to Contra party)
Special Price Indicator	49	X(1)	Y = Special Price, b = Not Special Price
Filler	50	X(1)	Reserved for Future Use
Special Price Memo	51-100	X(50)	User Memo (may be displayed to Contra party)
Contra Branch Sequence	101-108	X(8)	Optional field, eight (8) alphanumeric
Trade Date	109-116	9(8)	mmddyyy format; Must be entered for all as-of and reversal transactions
Reversal Indicator	117	X(1)	b=not a Reversal, R = Reversal
Automatic Giveup Flag	118	X(1)	Contains “Y” if Automatic Giveup;

Field Name	Position	Format	Contents/Comments
			Blank otherwise. (Note: AGU transactions must be entered from the Seller's point of view.)
Reserved field	119-130	X(12)	Reserved Field
CR LF			Carriage Return, Line Feed

## 4.0 SWITCH OUTPUT MESSAGES

Input messages received from TRACE subscribers will be forwarded to the TRACE System for processing through the NASDMS Switch. Identical to currently existing CTCI applications (i.e., ACT Trade Report, SOES etc.), the NASDMS Switch will perform the Switch validations for each TRACE input message received. The NASDMS Switch will always generate a response back to the originator for each input message received. The response can be a positive acknowledgment if the input messages pass the switch validation, or a negative acknowledgment, or a rejection if the input messages fail the Switch validation.

All output message (Switch or application output messages) forwarded by the Switch to an output destination (i.e., subscriber station) will be contained in the Switch Output Message Envelope format.

### 4.1 TRACE Application Output Messages

A TRACE input message that successfully passes the Switch validations is forwarded to the TRACE application, which will perform additional validations on the text of the input message. If an error is detected, the originating subscriber shall receive a reject message explaining why the original message could not be processed. If no errors are detected and TRACE accepts the input message, the TRACE application will send an acknowledgment message to the originating subscriber and a Notification message to the contra party. All Reject and Notification messages released from the TRACE Application Processor will be forwarded to the subscriber via the NASDMS Switch in Switch Output Message format if the subscriber is employing a CTCI and will be contained in a Switch Output Message Envelope. Note that if the rejected text is too large, the Switch Trailer will overlay the text such that the block does not exceed 1024 characters.

For TRACE, all Reject messages will contain a priority code. This code will indicate to firms the urgency to which action should be taken to correct and resubmit a rejected trade report. The two codes that will be utilized are 'H' for High Priority and 'L' for Low Priority. The priority code will follow the Status on Line 2 of the Reject message. The Reject Priority code is determined based on the reported bond's dissemination status, i.e., if a bond is designated to be disseminated and is rejected on a trade report, the Reject Priority will be High (H). If the bond is not designated to be disseminated, or the bond (CUSIP) is not maintained in our records, the Reject Priority will be Low (L).

There is no guarantee that TRACE messages will be received in a logical sequence. Subscribers should take this into consideration in their design.

### 4.2 Reject Message Format

If the TRACE application cannot process a message received from the subscriber, it will generate a Status Message for the originator which indicates why the message was rejected. The Status Message will be received by the originator as the text portion of a Standard Switch Output Message. The text (Status Message) is described below.

<u>Line 1:</u>		
<b>Originator MPID -</b>		This is an optional line that may contain the four character MPID of the entering firm, or the MPID of the firm the Service Bureau is acting for. If this option is utilized for multistation lines, it will equal the four character MPID associated with the station (select/poll address).
<b>CR LF -</b>		Required line delimiter.
<u>Line 2:</u>		
<b>Category and Priority -</b>		This field identifies the message category and will contain "STATUS". In addition, the line will contain the priority code of the reject, either H to indicate High or L to indicate Low. A space will separate the category and priority.
<b>CR LF -</b>		Required line delimiter.
<u>Line 3:</u>		This line contains ("REJ - Reason for Rejection").
<b>CR LF -</b>		Required line delimiter.
<u>Line 4:</u>		
<b>Branch Office Code and Sequence Number</b>		This line of the Status Message contains the one to eight alphabetic character Branch Office Code Sequence Number which appears on line 1 of the input message, if one was submitted. In addition, a time field (HH:MM:SS) will be sent on this line. If a Branch Office Code Sequence Number were not entered in the input message, Line 4 contains only the time message.
<b>CR LF -</b>		Required line delimiter.
<u>Line 5:</u>		This line contains an echo of the original input message being rejected.
<b>CR LF -</b>		Required line delimiter.

**EXHIBIT 4.2**  
**TRACE REJECT MESSAGE FORMAT**

Line 1: MPID cr lf  
Line 2: STATUS H (or) L cr lf (see note below)  
Line 3: REJ - (Reject Reason) cr lf  
Line 4: BRIDSQNO HH:MM:SS cr lf  
Line 5: (Text of original input message) cr lf

*Note:* Line 2 will end with a value of either H or L to indicate that the reject is either a High priority or Low priority.

**4.3 TRACE UM Notification Message**

If a TRACE input message (i.e., Trade Entry, Cancel, No/Was) is accepted by the TRACE application (i.e., it passes all validations), an appropriate UM Notification Message will be forwarded to the proper

TRACE subscriber. The TRACE UM Notification Messages contain sufficient data to enable subscribers to build their own TRACE Image Files to perform trade reporting procedures. If the firm selected header options but has not specified customized headers, then the default message header origin will be TRACEXXX where XXX represents 1 - 3 alphanumeric characters and the default message header type field will contain T (OTHER). Following the optional header line(s), the UM notification message will be received by the subscriber as the text portion of a Standard Switch Output Message and is described below:

Line 1:

**OTHER MPID** - Receiving firm MPID.  
**CR LF** - Required line delimiter.

Line 2:

**TRACE Message Type** - This field identifies the TRACE UM Notification message header and will contain the type of message being sent. See Section 4.4 for a list of Output Message Types.

Line 3:

**Message Detail** This line is the detail data of the UM Notification Message corresponding to the Output Message Type specified in Line 2. See Section 4.4 for a description of the message formats associated with each Output Message Type.

#### **4.4 Message Format Definitions**

**BCEN -** denotes a TRACE Entry Acknowledgment Message. When firm enters an original or As-of trade and the trade is accepted by TRACE, this message will be forwarded to the originator.

**BCAN -** denotes a Cancel TRACE UM Notification Message. If a trade is canceled, this message will be forwarded to both parties.

**BCNW-** denotes a No/Was TRACE UM Notification Message. This message will be forwarded to the trading parties as follows when a firm submits a No/Was transaction:

- 1) The BCNW Message will always be forwarded to the updating firm.
- 2) The BCNW Message will be forwarded to the contra.

**BCAL -** denotes a TRACE Entry Allege Notification Message. When a firm enters an original or As-of trade and the trade is accepted by TRACE, this message will be forwarded to the contra party.

Note: If a subscriber chooses to build a TRACE Image File, which contains all trades entered by the firm or trades other firms entered against the firm, then respective BCEN and BCAL messages should be used to build it. Other TRACE UM messages described below will be used to update the statuses and/or contents of these trades.

## 5.0 TRADE REPORTING OUTPUT MESSAGES

### 5.1 Acknowledgment Message (BCEN)

#### 5.1.1 TRACE Trade Entry Acknowledgment Message (BCEN)

**BCEN:** denotes a TRACE Entry Acknowledgment Notification Message. When a firm enters a TRACE trade entry and the entry is accepted by TRACE, this message will be forwarded to the originator. This message is formatted as follows:

LINE 1: Other MPID Cr Lf  
LINE 2: BCEN Cr Lf  
LINE 3: Control Number (Trade Text) Cr Lf

Where:

**MPID -** Receiving firm MPID

**Control Number -** The ten digit control number which the TRACE System had assigned to the TRACE trade when it was accepted by the TRACE System. The control number is required to uniquely identify the record in the TRACE File for subsequent processing.

**Trade Text -** This field contains the TRACE trade and will be formatted as a TRACE Trade Entry Message. The function field will contain the status of the trade.

**Cr Lf -** Required line delimiter.

Note 1: Valid TRACE statuses are:

C - Canceled  
N - No  
W - Was  
T - Trades entered for Ticker only



**Exhibit 5.1 TRACE Trade Entry Acknowledgment - (BCEN)**

**Two Part Message**

Field Name	Position	Format	Contents/Comments
<b>Line 1</b>			
Message Type	1-4	X(4)	“BCEN
Filler	5	X	One Null Byte
Control Number	6-15	9(10)	Control Number Assigned to Trade
Trade Status	16	X(1)	Status of Trade
As-of	17	X(1)	Y=As-of (T+1 to T+n); b=Original (T Day entry)
B/S	18	X(1)	B=Bought, S=Sold
Reference Number	19-38	X(20)	User assigned reference number, not validated by system.
Volume	39-50	9(12)	Report the actual number of bonds traded. Format 9(7) v 9(5)
Symbol	51-64	X(14)	Bond symbol
CUSIP	65-73	X(9)	Bond CUSIP
When-Issued Indication	74	X(1)	Y = Yes, N = No
Price	75-84	X(10)	Numeric Field, Price at which bond traded. Format 9(4)V9(6)
Yield Sign	85	X(1)	“-“ Yield is negative
Yield	86-97	9(12)	The yield at which the transaction was effected. For when-issued bonds, Yield is not required <b>unless Price is not provided.</b>
Seller Commission	98-105	9(8)	Commission format 9(2)V9(6)
Buyer Commission	106-113	9(8)	Commission format 9(2)v9(6)
CR, LF			Carriage Return, Line Feed
<b>Line 2</b>			
Trade Modifier	1-3	X(3)	SNN=Seller, C=Cash, ND=Next Day, W=Weighted Average, b=Regular
Price Override	4	X(1)	O=Override, b=No override
CPID	5-8	X(4)	MPID of the Contra Party. “C” for Customer may be entered by the Reporting party.
CPGU	9-12	X(4)	MPID of give up on the Contra side
CP Clear Number	13-16	9(4)	Contra Party’s clearing Number, b=Major clearing Number
RPID	17-20	X(4)	Required MPID of the Reporting Party
RPGU	21-24	X(4)	MPID of give up on the Reporting side
RP Clear Number	25-28	9(4)	Reporting Party’s clearing Number, b=Major clearing Number
Seller PA Indicator	29	X(1)	P or b=Principal, A=agent
Buyer PA Indicator	30	X(1)	P or b=Principal, A=agent
Filler	31-32	X(2)	Reserved for Future Use
Execution Time	33-38	9(6)	Execution Time in HHMMSS format.
Internal Memo	39-48	X(10)	User Memo (Will not be displayed to Contra party)
Special Price Indicator	49	X(1)	Y=Special Price, b= Not Special Price
Filler	50	X(1)	Reserved for Future Use

<b>Field Name</b>	<b>Position</b>	<b>Format</b>	<b>Contents/Comments</b>
Special Price Memo	51-100	X(50)	User Memo (may be displayed to Contra party)
Contra Branch Sequence	101-108	X(8)	Optional field, eight (8) alphanumeric
Trade Date	109-116	9(8)	mmddyyy format; Must be entered for all as-of and reversal transactions
Reversal Indicator	117	X(1)	b=not a Reversal, R = Reversal
Append Modifier	118-120	X(3)	Shows the second modifier (.A, .SLD) or nothing
Automatic Giveup Flag	121	X(1)	Contains "Y" if Automatic Giveup; Blank otherwise. (Note: AGU transactions must be entered from the Seller's point of view.)
Reserved Field	122-133	X(12)	Reserved for Future Use
CR, LF			Carriage Return, Line Feed

## **5.2 *Allege Messages (BCAL)***

### **5.2.1 TRACE Trade Entry Allege Message (BCAL)**

**BCAL:** Denotes a TRACE Entry Allege Notification Message. When a firm enters a TRACE trade entry and the entry is accepted by TRACE, this message will be forwarded to the contra party. This message is formatted as follows:

LINE 1: Other MPID Cr Lf  
LINE 2: BCAL Cr Lf  
LINE 3: Control Number (Trade Text) Cr Lf

Where:

**MPID -** Receiving firm MPID

**Control Number -** The ten digit control number which the TRACE System had assigned to the TRACE trade when it was accepted by the TRACE System. The control number is required to uniquely identify the record in the TRACE File for subsequent processing.

**Trade Text -** This field contains the TRACE trade and will be formatted as a TRACE Trade Entry Message (Section 3.1). The function field will contain the status of the trade.

**Cr Lf -** Required line delimiter.

**Exhibit 5.2 TRACE Trade Entry Allege Message - (BCAL)**

**Two Part Message**

Field Name	Position	Format	Contents/Comments
<b>Line 1</b>			
Message Type	1-4	X(4)	“BCAL
Filler	5	X	One Null Byte
Control Number	6-15	9(10)	Control Number Assigned to Trade
Trade Status	16	X(1)	Status of Trade
As-of	17	X(1)	Y=As-of (T+1 to T+n); b=Original (T Day entry)
B/S Indicator	18	X(1)	B=Bought, S=Sold
Reference Number	19-38	X(20)	User assigned reference number, not validated by system.
Volume	39-50	9(12)	Report the actual number of bonds traded. Format 9(7) v 9(5)
Symbol	51-64	X(14)	Bond symbol
CUSIP	65-73	X(9)	Bond CUSIP
When-Issued Indication	74	X(1)	Y = Yes, N = No
Price	75-84	X(10)	Numeric Field, Price at which bond traded. Format 9(4)V9(6)
Yield Sign	85	X(1)	“-“ Yield is negative
Yield	86-97	9(12)	The yield at which the transaction was effected. For when-issued bonds, Yield is not required <b>unless Price is not provided..</b> Format 9(6) v 9(6)
Seller Commission	98-105	9(8)	Commission format 9(2)V9(6)
Buyer Commission	106-113	9(8)	Commission format 9(2)v9(6)
CR, LF			Carriage Return, Line Feed
<b>Line 2</b>			
Trade Modifier	1-3	X(3)	SNN=Seller, C=Cash, ND=Next Day, W=Weighted Average, b=Regular
Price Override	4	X(1)	O=Override, b=No override
CPID	5-8	X(4)	MPID of the Contra Party. “C” for Customer may be entered by the Reporting party.
CPGU	9-12	X(4)	MPID of give up on the Contra side
CP Clear Number	13-16	9(4)	Contra Party’s clearing Number, b=Major clearing Number
RPID	17-20	X(4)	Required MPID of the Reporting Party
RPGU	21-24	X(4)	MPID of give up on the Reporting side
RP Clear Number	25-28	9(4)	Reporting Party’s clear Number, b=Major clear Number
Seller PA Indicator	29	X(1)	P or b=Principal, A=agent
Buyer PA Indicator	30	X(1)	P or b=Principal, A=agent
Filler	31-32	X(2)	Reserved for Future Use
Execution Time	33-38	9(6)	Execution Time in HHMMSS format.
Internal Memo	39-48	X(10)	User Memo (Will not be displayed to Contra party)
Special Price Indicator	49	X(1)	Y=Special Price, b= Not Special Price
Filler	50	X(1)	Reserved for Future Use

<b>Field Name</b>	<b>Position</b>	<b>Format</b>	<b>Contents/Comments</b>
Special Price Memo	51-100	X(50)	User memo (may be displayed to the Contra party)
Contra Branch Sequence	101-108	X(8)	Optional field, eight (8) alphanumeric
Trade Date	109-116	9(8)	mmddyymm format; Must be entered for T+2 or older
Reversal Indicator	117	X(1)	b=not a Reversal, R = Reversal
Append Modifier	118-120	X(3)	Shows the second modifier (.A,SLD) or nothing if not needed
Automatic Giveup Flag	121	X(1)	Contains "Y" if Automatic Giveup; Blank otherwise. (Note: AGU transactions must be entered from the Seller's point of view.)
Filler	122-133	X(12)	Filler Reserved for Future Use.
CR, LF			Carriage Return, Line Feed

### 5.3 Cancel Trade Acknowledgment (BCAN)

**Reference Number -** A twenty character alphanumeric field provided by the subscriber. A firm's own reference number will be returned.

**Control Number -** The ten digit control number which the TRACE System had assigned to the TRACE transaction when it was originally received from the subscriber. The control number is required to uniquely identify the canceled TRACE record in the TRACE File.

**CR LF -** Required line delimiter.

#### **EXHIBIT 5.3** **TRACE UM NOTIFICATION MESSAGE - BCAN**

LINE 1: OTHER MPID cr lf  
LINE 2: BCAN cr lf  
LINE 3: (REF Number) (Control Number) cr lf

##### **Exhibit 5.3.1 Cancel Trade Acknowledgment (BCAN)**

<b>Field Name</b>	<b>Position</b>	<b>Format</b>	<b>Contents/Comments</b>
Reference Number	1-20	X(20)	User assigned Reference Number
Control Number	21-30	9(10)	Control Number associated with the canceled TRACE record

#### **5.4 No/Was TRACE UM Notification (BCNW)**

Denotes a TRACE No/Was TRACE UM Notification Message. This message will be forwarded to the trading parties as follows when a firm submits a No/Was transaction:

- 1) The BCNW Message will always be forwarded to the updating firm.
- 2) The BCNW Message will be forwarded to the contra party if the contra in the No trade equals the contra in the Was trade (i.e., no change in the CPID).

<b>"NO" Reference Number</b>	Twenty character alphanumeric field provided by the subscriber. A firm's own reference number will be returned.
<b>"NO" Control Number</b>	A ten digit TRACE assigned control number which will be used to identify the "NO" part of the No/Was trade.
<b>"Was" Control Number</b>	A ten digit TRACE assigned control number which will be used to identify the "Was" part of the No/Was trade.
<b>WAS TEXT</b>	The WAS TEXT is identical to the "Was Portion" of a NO/WAS entry message preceded by the status.
<b>CR LF</b>	Required line delimiter.

#### **EXHIBIT 5.4** **TRACE UM NOTIFICATION MESSAGE - BCNW**

LINE 1: OTHER MPID cr lf  
LINE 2: BCNW cr lf  
LINE 3: (NO REF Number) (No Control #)(WAS Control Number) (WAS Text) cr lf

Note 1: The WAS Text is identical to the Trade Text formatted as an RP Trade Entry.

**Exhibit 5.4.1 TRACE No/Was UM Notification (BCNW)**

**Two Part Message**

Field Name	Position	Format	Contents/Comments
<b>Line 1</b>			
NO Reference Number	1-20	X(20)	User assigned Reference Number of the NO Trade
Control Number	21-30	9(10)	Control Number of the No trade
WAS Control Number	31-40	9(10)	Control Number assigned to the WAS portion of the trade
Trade Status	41	X(1)	Status of Trade
As-of	42	X(1)	Y=As-of (T+1 to T+n); b=Original (T Day entry)
B/S	43	X(1)	B=Bought, S=Sold
Reference Number	44-63	X(20)	User assigned reference number
Volume	64-75	9(12)	Report the actual number of bonds traded. Format 9(7) v 9(5)
Symbol	76-89	X(14)	Bond symbol
CUSIP	90-98	X(9)	Bond CUSIP
When-Issued Indication	99	X(1)	Y = Yes, N = No
Price	100-109	9(10)	Dollar price format 9(4) v 9(6)
Yield Sign	110	X(1)	“-“ Yield is Negative, Blank - Yield is Positive
Yield	111-122	9(12)	The yield at which the transaction was effected. For when-issued bonds, Yield is not required <b>unless Price is not provided</b> . Format 9(6)v9(6)
Seller Commission	123-130	9(8)	Commission format 9(2) v 9(6)
Buyer Commission	131-138	9(8)	Commission format 9(2) v 9(6)
CR, LF			Carriage Return, Line Feed
<b>Line 2</b>			
Trade Modifier	1-3	X(3)	SNN=Seller, C=Cash, ND=Next Day, W=Weighted Average, b=Regular
Price Override	4	X(1)	O=Override, b=No override
CPID	5-8	X(4)	MPID of the Contra Party. “C” for Customer may be entered by the Reporting party.
CPGU	9-12	X(4)	MPID of give up on the Contra side
CP Clear Number	13-16	9(4)	Contra Party’s clearing Number, b=Major clearing Number
RPID	17-20	X(4)	Required MPID of the Reporting Party
RPGU	21-24	X(4)	MPID of give up on the Reporting side
RP Clear Number	25-28	9(4)	Reporting Party’s clearing Number, b=Major clearing Number
Seller PA Ind.	29	X(1)	P or b=Principal, A=agent
Buyer PA Ind.	30	X(1)	P or b=Principal, A=agent
Filler	31-32	X(2)	Reserved for Future Use
Execution Time	33-38	9(6)	Execution Time in HHMMSS format.
Internal Memo	39-48	X(10)	User Memo (Will not be displayed to Contra party)
Special Price Indicator	49	X(1)	Y = Special Price, b = Not Special Price
Filler	50	X(1)	Reserved for Future Use
Special Price Memo	51-100	X(50)	User Memo (may be displayed to Contra party)
Contra Branch Sequence	101-108	X(8)	Optional field, eight (8) alphanumeric
Trade Date	109-116	9(8)	mmddyyyy format; Must be entered for all as-of and reversal transactions
Reversal Indicator	117	X(1)	b=not a Reversal, R = Reversal



Append Modifier	118-120	X(3)	Shows the second modifier (.A,SLD) or nothing if not needed
Automatic Giveup Flag	121	X(1)	Contains "Y" if Automatic Giveup; Blank otherwise. (Note: AGU transactions must be entered from the Seller's point of view.)
Reserved field	122-133	X(12)	Reserved Field
CR, LF			Carriage Return, Line Feed



# APPENDIX A --- TCP/IP Connection NASDAQ CTCI TCP/IP Client Interface Specification

## *Purpose*

The purpose is to describe how a subscriber can submit and receive messages to and from The Nasdaq Stock Market's Computer to Computer Interface (CTCI) using the TCP/IP protocol.

**Note:** Nasdaq no longer supports the X.25 protocol for CTCI connectivity. If your firm currently uses X.25 for FIPS CTCI, please call Judy Schwarz at (203) 385-4675 or Beverly Hinds-Brown at (203) 385-4502 for important information on migrating from FIPS to TRACE CTCI connectivity.

## *Organization*

The information contained in this appendix is presented in a step by step sequence that describes what must be done to setup and configure a TCP/IP connection with Nasdaq, how to establish a TCP/IP connection, what control messages and associated protocol must be supported for CTCI TCP/IP session management, and ultimately how to send and receive CTCI messages over a TCP/IP connection. Here is how the appendix is organized:

- The business of contacting Nasdaq and configuring how the subscriber will access Nasdaq through TCP/IP, is discussed first under **Setup** and **Testing**.
- Next the basics of establishing a TCP/IP connection with Nasdaq is discussed in **Establishing a TCP/IP Connection**.
- The format of the CTCI TCP/IP Message is presented next in **CTCI TCP/IP Message Format**. This format is used for sending and receiving the CTCI message itself and also for sending and receiving control messages necessary for session management.
- A discussion of session management follows in **CTCI TCP/IP Session Management**, followed by detailed descriptions and examples of each control message in **Control Messages**.
- Finally, the method and format for sending and receiving CTCI messages is described in **Sending a CTCI Message, Receiving a CTCI Message** and **CTCI Message Sequence Verification**.

The subscriber should read this appendix from beginning to end to be sure that the rules of the protocol, and what the subscriber is required to do to use it, are clearly understood prior to contacting Nasdaq for Setup.

## *Setup*

Before attempting to establish a connection over TCP/IP, the subscriber must first contact Nasdaq to configure the connection. More than one TCP/IP connection can be configured for the same subscriber, if necessary. For each connection, Nasdaq will provide the subscriber with two pairs of IP Addresses and a Well Known Port to connect to (the same port is used for all four addresses). At the same time, the

subscriber must provide Nasdaq with the IP Address that they will be connecting from when they establish the connection.

Note: The four IP Addresses consist of a Primary address and an Alternate address for use in connecting to Nasdaq and a backup address pair for use in connecting to the Nasdaq Disaster Recovery (D.R.) site. Please see Section A.5 for more details.

For each TCP/IP connection, a client profile must be established. This involves assigning an agreed upon ten character logon identifier and assigning meaning to the “logical channels” that the subscriber will use to exchange CTCI messages with Nasdaq. *Note: A method of encryption will be introduced in future releases.*

The logon identifier will be associated with the IP Address the client will be connecting from, and the IP Addresses and Well Known Port the client should be connecting to. This information will be verified when the client establishes the connection and sends a Logon control message to Nasdaq.

Over one TCP/IP connection, a subscriber can submit and receive CTCI messages on behalf of up to 63 different users and/or device locations. Messages for each user or device location are kept separated from each other by assigning them each to their own logical channel. Together with Nasdaq, the subscriber assigns a logical channel number from 1 to 63 to each of the users or device locations that the subscriber will be submitting and receiving CTCI messages on behalf of.

Use of a logical channel is up to the subscriber. A logical channel may be used for sending-only, receiving-only or both. This is solely under control of the subscriber.

## ***Testing***

The Customer Subscriber Test System will be available, but the subscriber will have to connect to a different IP Address and Well Known Port from production. The subscriber should contact Nasdaq to obtain an IP Address and Well Known Port to connect to for testing. This means the subscriber must maintain the ability to dynamically connect to different sockets.

## ***Establishing a TCP/IP Connection***

The client (the subscriber) establishes a TCP/IP connection with the server (Nasdaq) by connecting to an IP Address and Well Known Port provided by Nasdaq, from the IP Address that the subscriber told Nasdaq they would be connecting from.

Note: The Nasdaq server follows the *Berkley Model* for establishing a socket connection.

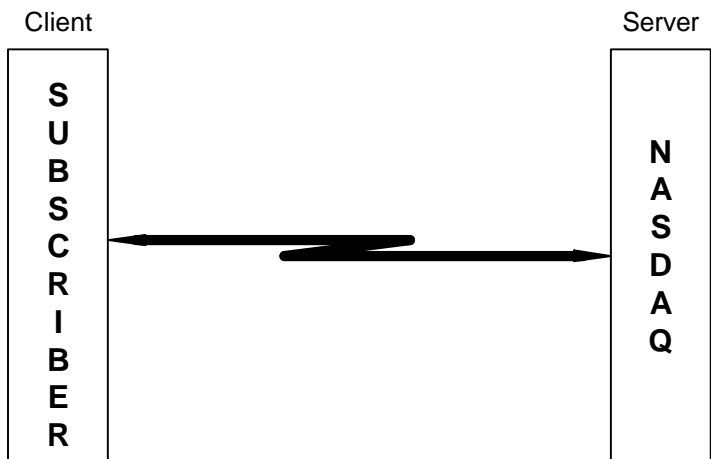

Retrying failed connection attempts:

The initial attempt to establish a TCP/IP connection should be to the Nasdaq Primary Address. If this attempt fails, the subscriber should delay briefly (3 seconds is recommended) and then try the Nasdaq Alternate Address. Subsequent attempts should alternate between the Primary and Alternate addresses until at least 30 seconds have elapsed. At that point the subscriber should make one attempt using the Disaster Recovery Primary Address, followed by one attempt to the Disaster Recovery Alternate Address. If a session still cannot be established, the entire cycle should begin again, starting with the Nasdaq Primary Address.

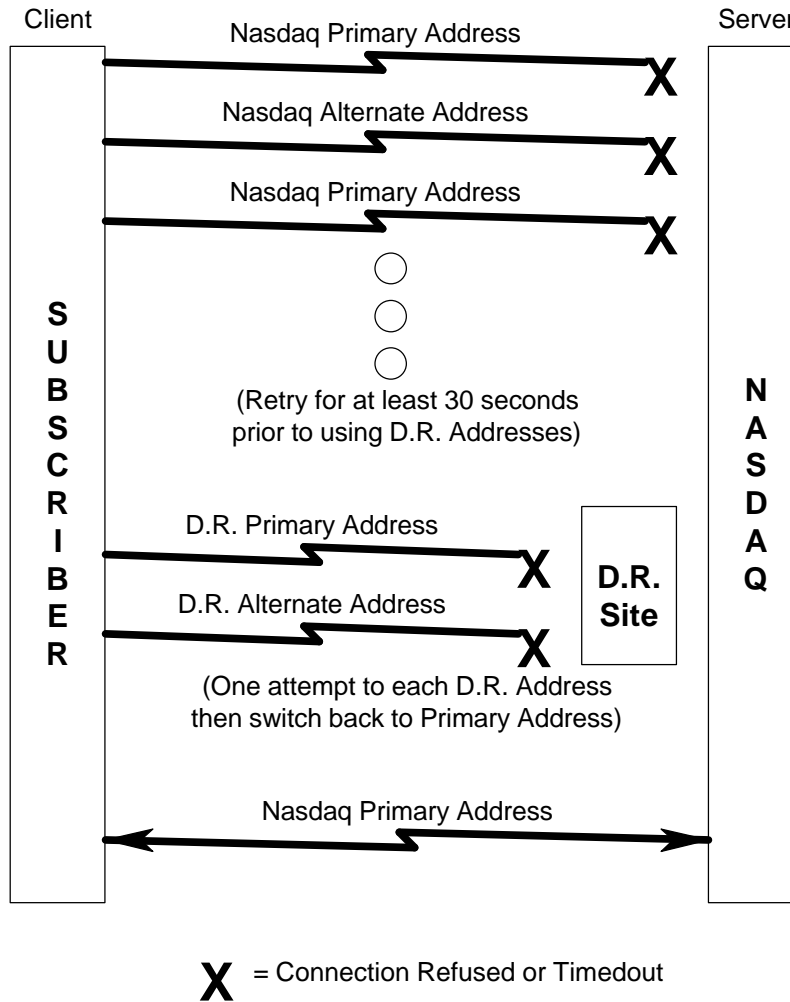

## CTCI TCP/IP Message Format

The CTCI TCP/IP Message is used for sending and receiving CTCI messages, as well as session management control messages. The CTCI TCP/IP Message consists of a message “envelope” and the CTCI or control message data.

When the CTCI TCP/IP Message contains CTCI message data it is referred to as a CTCI message, and when it contains a control message it is referred to by the name of the control message (Logon, Heartbeat Query, etc.). The format of the CTCI TCP/IP Message is as follows:

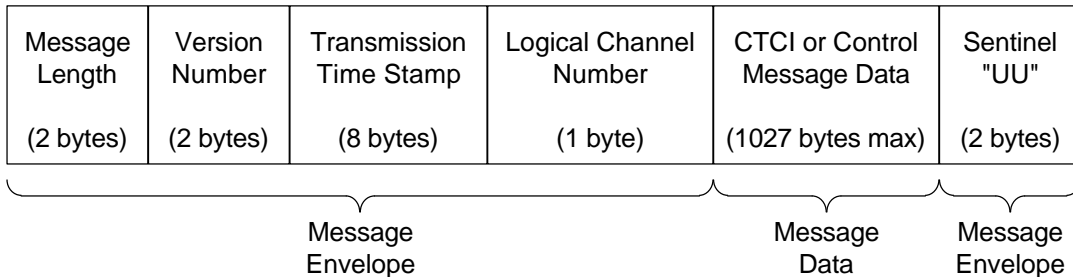

The *Message Length* is a binary field that contains the total length of the CTCI TCP/IP Message **including** the Message Length field at the beginning and the Sentinel field at the end. Currently, the largest message that can be sent is 1042 bytes. The Message Length field is the “sentinel boundary” of the message. Data flow must begin on a sentinel boundary whenever a connection is established.

The *Version Number* contains a two character ASCII string. The first character contains the integer portion of the version number and the second character contains the decimal portion of the version number. This is version 1.0 of the interface, so the value in the first byte will be one and the value in the second byte will be zero.

The *Transmission Time Stamp* is an ASCII numeric field containing the time the CTCI TCP/IP Message was transmitted in HHMMSSCC (see Glossary) format.

The *Logical Channel Number* is a binary field that contains a value from zero through 63. If the logical channel number is zero, the CTCI TCP/IP Message is a control message. If the logical channel number is one through 63, the message is a CTCI message, and the logical channel number indicates which user or device location that the CTCI message belongs to.

*CTCI or Control Message Data* contains the CTCI or control message data. When the logical channel number is one through 63 it contains CTCI message data. When the logical channel number is zero, CTCI or Control Message Data contains the fields of one of the control messages described in the following pages.

The *Sentinel* is an ASCII field that always contains a constant of “UU”.

## **CTCI TCP/IP Session Management**

The control messages listed below are used for session management and will be exclusively sent over logical channel zero. The format, content and more detail about how each control message should be used is described in the pages that follow the session management discussion:

- Logon
- Logon Response
- Heartbeat Query
- Heartbeat Response
- Flow Control
- Logical Channel State Query
- Logical Channel State Response

Once a socket connection is established, the very first thing the client must do is send a Logon control message to the server. The Logon Identifier field tells the server who the client is, the Logical Channel State fields tell the server on which logical channels the client is ready to receive CTCI messages. If the Logon fails, the connection will be broken by Nasdaq. If the Logon is successful the server will send a Logon Response control message back to the client.

On the Logon Response control message the Logical Channel State fields tell the client on which logical channels the server is ready to receive CTCI messages. The client must not send CTCI messages to the server over any logical channel that is in not in a “ready to receive” state. ***If a logical channel is not in a “ready to receive” state, and the client sends CTCI messages over it to the server, the messages will be discarded.***

*Note: It is not necessary to verify that logical channel zero is ready to receive. This logical channel must always be in a “ready to receive” state, as there must always be a dedicated path open for control message exchange.*

The client can now send CTCI messages over any logical channel that the server has indicated is ready to receive. If the client has no CTCI or control messages to be sent over any logical channel on a connection, or there are no logical channels (1-63) that server is ready to receive them on, the client must send a Heartbeat Query control message on logical channel zero every 10 seconds.

For logical channels that the server has indicated are not ready to receive, the client must wait until the server changes the logical channel state to ready to receive. The server will do this by sending the client a Flow Control control message on logical channel zero.

In the event that the volume of CTCI message traffic over a logical channel becomes too much for a message receiver (client or server) to buffer and process, the message receiver can instruct the sender to suspend transmission on the logical channel by sending a Flow Control control message that places the logical channel in a “not ready to receive” state. When the receiver is ready to resume receiving messages on the logical channel again, the receiver sends a Flow Control control message that returns the logical channel to a “ready to receive” state.

At any time during the session, the client (or server) may request the state of a logical channel by sending a Logical Channel State Query Request to the server (or client). The server (or client) must respond with a Logical Channel State Query Response that informs the receiver whether the logical channel is in a “ready to receive”, “not ready to receive” or “not configured” state.



The last two bytes of every CTCI TCP/IP Message received should always be checked for the sentinel character string of “UU”. If the last two bytes are not equal to the sentinel, the TCP/IP connection is considered no longer reliable and should be terminated.

## Control Messages

### Logon and Logon Response

Once a socket connection is established, the very first thing the client must do is send a Logon control message to the server.

If the server does not recognize the Logon Identifier as being associated with the IP Address the client has connected from, or does not recognize the Logon Identifier as being associated the IP Address and Well Known Port the client is connected to, it will terminate the connection. If the Logon is successful a Logon Response control message will be returned.

Here is an example of a *Logon* control message sent on logical channel zero at 9:30AM:

Message Length (2 bytes) <b>Value: 92</b>	Version Number (2 bytes) <b>Value: 10</b>	Transmission Time Stamp (8 bytes) <b>Value: 09300000</b>	Logical Channel Number (1 byte) <b>Value: zero</b>	Control Message Data (77 bytes)	Sentinel (2 bytes) <b>Value: UU</b>			
				<table border="1"> <tr> <td>Control Message Type (3 bytes) <b>Value: LGQ</b></td> <td>Logon Identifier (10 bytes) <b>Value: ABCD</b></td> <td>Logical Channel States (64 bytes) <b>Values: 1,2,1,zero,zero...</b></td> </tr> </table>		Control Message Type (3 bytes) <b>Value: LGQ</b>	Logon Identifier (10 bytes) <b>Value: ABCD</b>	Logical Channel States (64 bytes) <b>Values: 1,2,1,zero,zero...</b>
Control Message Type (3 bytes) <b>Value: LGQ</b>	Logon Identifier (10 bytes) <b>Value: ABCD</b>	Logical Channel States (64 bytes) <b>Values: 1,2,1,zero,zero...</b>						

In this example, the *Logical Channel Number* contains a value of zero, indicating the message is a control message.

The *Control Message Type* is an ASCII field that appears in every control message that indicates which control message is being sent. In this case “LGQ” represents Logon.

The *Logon Identifier* field is an ASCII field that must contain the logon identifier assigned during setup for use with the IP Address and Well Known Port. The value ABCD is shown just as an example.

In the *Logical Channel States* field, each byte contains a binary value that represents the state of a logical channel. The first byte contains the state of logical channel zero, the second the state of logical channel one, the third the state of logical channel three, up to the 64<sup>th</sup> byte that contains the state of logical channel 63. If the logical channel is ready to receive the value will be one. If it is not ready to receive the value will be 2. If the logical channel was not configured during Setup, the value will be zero.

In this example the value of the state of logical channel zero and two is one. The value of the state of logical channel one is two. The value of the state of logical channels three through 63 is zero. This means the client is ready to receive control messages on logical channel zero (always the case), not ready to receive CTCI messages on logical channel one, ready to receive CTCI messages on logical channel two, and the remaining logical channels are not configured.

Here is an example of a *Logon Response* control message sent on logical channel zero at 2/100 of a second past 9:30AM:

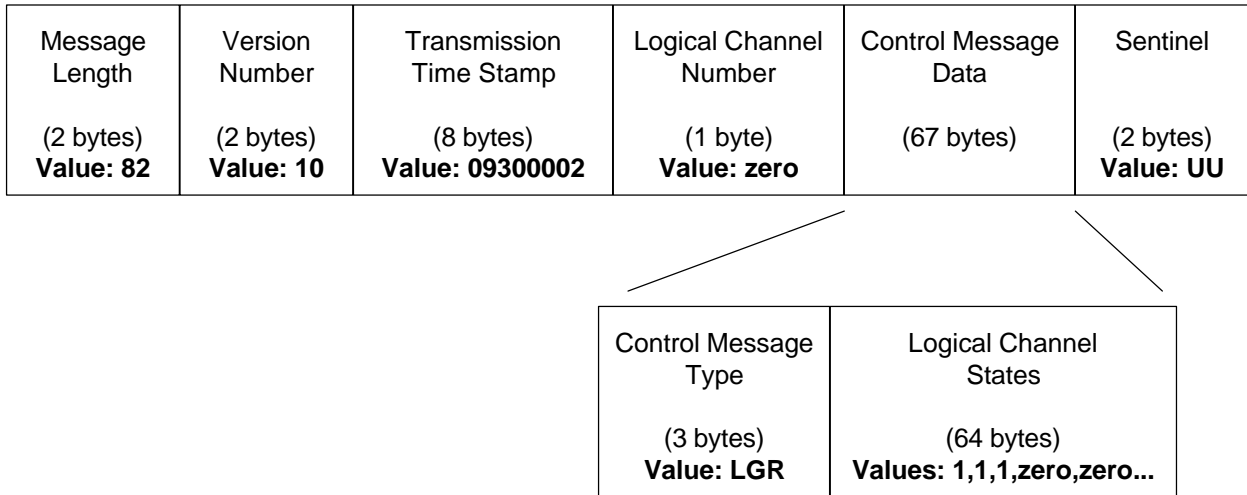

In this example, the *Logical Channel Number* contains a value of zero, indicating the message is a control message.

The *Control Message Type* is an ASCII field that appears in every control message that indicates which control message is being sent. In this case “LGR” represents Logon Response.

In the *Logical Channel States* field, each byte contains a binary value that represents the state of a logical channel. The first byte contains the state of logical channel zero, the second the state of logical channel one, the third the state of logical channel three, up to the 64<sup>th</sup> byte that contains the state of logical channel 63. If the logical channel is ready to receive the value will be one. If it is not ready to receive the value will be 2. If the logical channel was not configured during Setup, the value will be zero.

In this example the value of the state of logical channel zero is one. The value of the state of logical channel one and two is one. The value of the state of logical channels three through 63 is zero. This means the server is ready to receive control messages on logical channel zero (always the case) and CTCI messages on logical channels one and two. The remaining logical channels are not configured.

## Heartbeat Query and Response

The integrity of the data transfer connection must be constantly checked with the periodic exchange of client-issued Heartbeat Query and server-issued Heartbeat Response control messages.

If there are no other messages to be sent the client must send a Heartbeat Query every 10 seconds. The server does not require heartbeat queries during the 10 second interval if any properly formatted message has been received within the last 10 seconds, but will terminate the connection if no message is received for the duration of two, 10 second intervals.

Here is an example of a *Heartbeat Query* control message sent on logical channel zero at 2 seconds past 9:30AM:

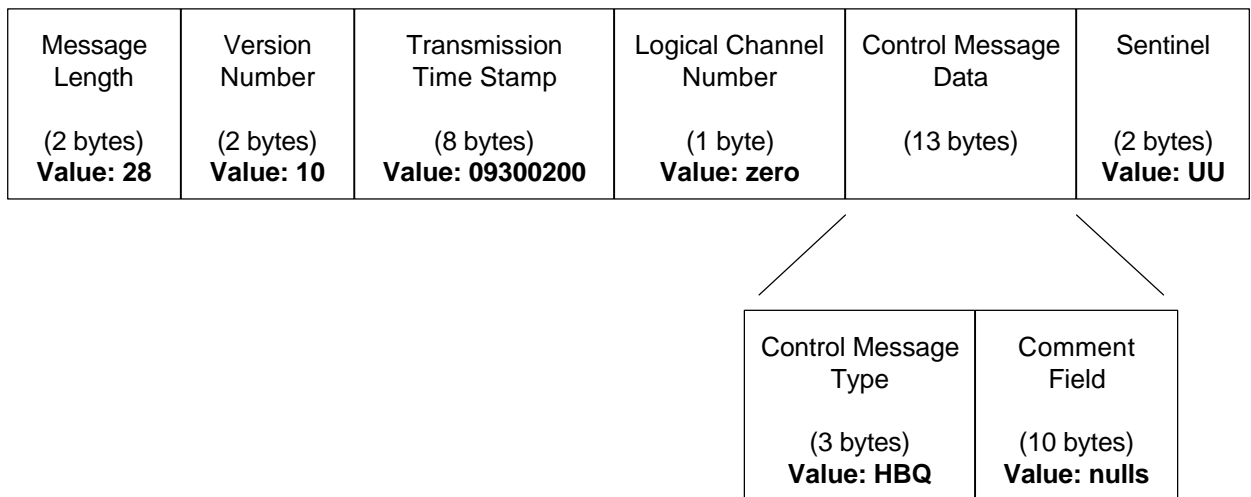

In this example, the *Logical Channel Number* contains a value of zero, indicating the message is a control message.

The *Control Message Type* is an ASCII field that appears in every control message that indicates which control message is being sent. In this case “HBQ” represents Heartbeat Query.

The *Comment* field is an ASCII field that the client can use. Any data in it will be echoed back in the Comment field of the Heartbeat Response. The complete ASCII character set can be used. If the field is not used, it should be filled with ASCII nulls (binary zeros). In this example, there is no data in the Comment field, so it is filled with nulls.

Here is an example of a *Heartbeat Response* control message sent on logical channel zero at 2 and 2/100 seconds past 9:36AM:

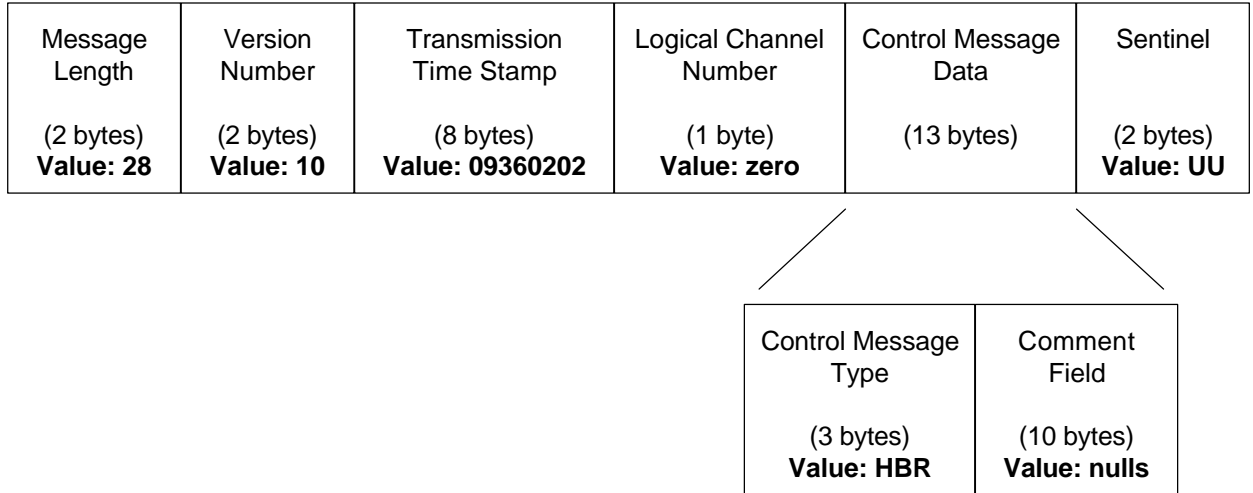

In this example, the *Logical Channel Number* contains a value of zero, indicating the message is a control message.

The *Control Message Type* is an ASCII field that appears in every control message that indicates which control message is being sent. In this case “HBR” represents Heartbeat Response.

The *Comment* field is an ASCII field that contains the data sent by the client in the Comment field of the Heartbeat Query. In this example the field contains nulls, echoing this area of the input message.

## Flow Control

In the event that the volume of CTCI message traffic over a logical channel becomes too much for a message receiver (client or server) to buffer and process, the message receiver can instruct the sender to suspend transmission on the logical channel by sending a Flow Control control message that places the logical channel in a “not ready to receive” state. When the receiver is ready to resume receiving messages on the logical channel again, the receiver sends a Flow Control control message that returns the logical channel to a “ready to receive” state.

*Note: Flow control of logical channel zero is not allowed, as there must always be a dedicated path open for control message exchange.*

Here is an example of a *Flow Control* control message sent on logical channel zero at 1:30PM that places logical channel one in a “not ready to receive” state:

Message Length (2 bytes) <b>Value: 28</b>	Version Number (2 bytes) <b>Value: 10</b>	Transmission Time Stamp (8 bytes) <b>Value: 13300000</b>	Logical Channel Number (1 byte) <b>Value: zero</b>	Control Message Data (13 bytes)	Sentinel (2 bytes) <b>Value: UU</b>
---	---	--	--	------------------------------------	---

Control Message Type (3 bytes) <b>Value: FLO</b>	Target Logical Channel Number (1 byte) <b>Value: 1</b>	Flow State (1 byte) <b>Value: 2</b>	Unused. (8 bytes) <b>Value: nulls</b>
--	--	---	---

In this example, the *Logical Channel Number* contains a value of zero, indicating the message is a control message.

The *Control Message Type* is an ASCII field that appears in every control message that indicates which control message is being sent. In this case “FLO” represents Flow Control.

The *Target Logical Channel Number* is a binary field that contains a value from one through 63 and indicates which logical channel should be affected. In this example, logical channel one is being affected.

The *Flow State* field is a binary field that changes the state of a logical channel to ready to receive or not ready to receive CTCI messages. A value of one changes the state to ready to receive. A value of two changes the state to not ready to receive. In this case the value is two, changing the state of the logical channel to “not ready to receive” CTCI messages.

The *Unused* field is an ASCII field that should always be filled with ASCII nulls (binary zeros).

Here is an example of a *Flow Control* control message sent on logical channel zero at 2:51PM that that places logical channel one in a “ready to receive” state:

Message Length	Version Number	Transmission Time Stamp	Logical Channel Number	Control Message Data	Sentinel
(2 bytes) <b>Value: 28</b>	(2 bytes) <b>Value: 10</b>	(8 bytes) <b>Value: 14510000</b>	(1 byte) <b>Value: zero</b>	(13 bytes)	(2 bytes) <b>Value: UU</b>

Control Message Type	Target Logical Channel Number	Flow State	Unused.
(3 bytes) <b>Value: FLO</b>	(1 byte) <b>Value: 1</b>	(1 byte) <b>Value: 1</b>	(8 bytes) <b>Value: nulls</b>

In this example, the *Logical Channel Number* contains a value of zero, indicating the message is a control message.

The *Control Message Type* is an ASCII field that appears in every control message that indicates which control message is being sent. In this case “FLO” represents Flow Control.

The *Target Logical Channel Number* is a binary field that contains a value from one through 63 and indicates which logical channel should be affected. In this example, logical channel one is being affected.

The *Flow State* field is a binary field that changes the state of a logical channel to ready to receive or not ready to receive CTCI messages. A value of one changes the state to ready to receive. A value of two changes the state to not ready to receive. In this case the value is one, changing the state of the logical channel to “ready to receive” CTCI messages.

The *Unused* field is an ASCII field that should always be filled with ASCII nulls (binary zeros).

## Logical Channel State Query and Response

The client or server can request the state of a particular logical channel by sending a Logical Channel State Query control message over logical channel zero. A Logical Channel State Response must be sent back by the query recipient.

Here is an example of a *Logical Channel State Query* control message requesting the state of logical channel one, sent on logical channel zero at 23 and 85/100 seconds past 1:45PM:

Message Length (2 bytes) <b>Value: 28</b>	Version Number (2 bytes) <b>Value: 10</b>	Transmission Time Stamp (8 bytes) <b>Value: 13452385</b>	Logical Channel Number (1 byte) <b>Value: zero</b>	Control Message Data (13 bytes)	Sentinel (2 bytes) <b>Value: UU</b>				
				<table border="1"> <tr> <td>Control Message Type (3 bytes) <b>Value: LCQ</b></td> <td>Target Logical Channel Number (1 byte) <b>Value: 1</b></td> <td>Unused (1 byte) <b>Value: nulls</b></td> <td>Comment (8 bytes) <b>Value: nulls</b></td> </tr> </table>		Control Message Type (3 bytes) <b>Value: LCQ</b>	Target Logical Channel Number (1 byte) <b>Value: 1</b>	Unused (1 byte) <b>Value: nulls</b>	Comment (8 bytes) <b>Value: nulls</b>
Control Message Type (3 bytes) <b>Value: LCQ</b>	Target Logical Channel Number (1 byte) <b>Value: 1</b>	Unused (1 byte) <b>Value: nulls</b>	Comment (8 bytes) <b>Value: nulls</b>						

In this example, the *Logical Channel Number* contains a value of zero, indicating the message is a control message.

The *Control Message Type* is an ASCII field that appears in every control message that indicates which control message is being sent. In this case “LCQ” represents Logical Channel State Query.

The *Target Logical Channel Number* is a binary field that contains a value from one through 63 and indicates for which logical channel the state is being requested. In this example the state of logical channel one is being requested.

The *Unused* field is an ASCII field that should always be filled with ASCII nulls (binary zeros).

The *Comment* field is an ASCII field that the message initiator can use. Any data present must be echoed back in the Comment field of the Logical Channel State Response. The complete ASCII character set can be used. If the field is not used, it should be filled with ASCII nulls (binary zeros).

Here is an example of a *Logical Channel State Response* control message returning the state of logical channel one, sent on logical channel zero at 24 seconds past 1:45PM:

Message Length (2 bytes) <b>Value: 28</b>	Version Number (2 bytes) <b>Value: 10</b>	Transmission Time Stamp (8 bytes) <b>Value: 13452400</b>	Logical Channel Number (1 byte) <b>Value: zero</b>	Control Message Data (13 bytes)	Sentinel (2 bytes) <b>Value: UU</b>
---	---	--	--	------------------------------------	---

Control Message Type (3 bytes) <b>Value: LCR</b>	Target Logical Channel Number (1 byte) <b>Value: 1</b>	Logical Channel State (1 byte) <b>Value: 2</b>	Comment (8 bytes) <b>Value: nulls</b>
--	--	--	---

In this example, the *Logical Channel Number* contains a value of zero, indicating the message is a control message.

The *Control Message Type* is an ASCII field that appears in every control message that indicates which control message is being sent. In this case “LCR” represents Logical Channel State Response.

The *Target Logical Channel Number* is a binary field that contains a value from one through 63 and indicates for which logical channel the state is being reported. In this example, the state of logical channel one is being reported.

The *Logical Channel State* is a binary field that contains a value that represents the state of the logical channel. If the logical channel is ready to receive, the value will be one. If it is not ready to receive, the value will be 2. If the logical channel was not configured during Setup, the value will be zero. In this example the value is two, indicating logical channel is “not ready to receive” CTCI messages.

The *Comment* field is an ASCII field that must always contain the data sent in the Comment field of the Logical Channel State Query. In this example the field contains nulls because that’s what was sent in the query.



## ***Sending a CTCI Message***

The client should format a CTCI message as usual (refer to the “**Subscriber Requirements for Computer to Computer Interface Utilizing the NASDMS Switch**” documentation), but to deliver it over a TCP/IP connection it must be imbedded in a CTCI TCP/IP Message “envelope”.

Here is an example of a CTCI message 100 bytes long sent on logical channel 31 at 9:31AM:

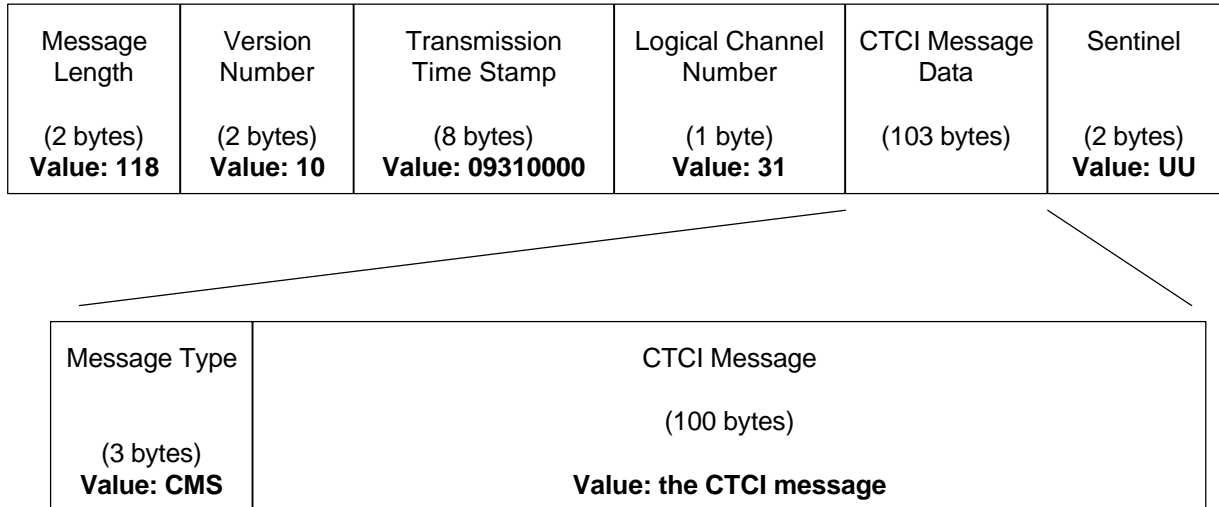

In this example, the *Logical Channel Number* contains a value of 31, in the range of one through 63, indicating that the message is a CTCI message.

The *Message Type* field is an ASCII field that should always have the value “CMS”..

*CTCI Message* is the actual CTCI message itself, beginning with line zero, line two, etc., as described in the “**Subscriber Requirements for Computer to Computer Interface Utilizing the NASDMS Switch**” documentation. Do not include any control characters other than those specific the composition of the CTCI message (i.e. carriage return and line feed).

## ***Receiving a CTCI Message***

NASDAQ will send CTCI messages to subscribers using the same format as described above in “Sending a CTCI Message”. The *CTCI Message* field will include any user-specified header line(s) followed by line zero, line two, etc., through any user-specified trailer line(s).

## ***CTCI Message Sequence Verification***

It is the responsibility of the client to detect and recover lost data by implementing CTCI message sequence number checking and message retrieval processing. It is also the responsibility of the client to respond to gap fill requests from the server for lost or discarded client to server messages. Refer to the “**Subscriber Requirements for Computer to Computer Interface Utilizing the NASDMS Switch**” documentation for a detailed description of these procedures. Message sequence numbers continue to be the last part of the *CTCI Message* in *CTCI Message Data*.

## APPENDIX B --- CTCI Rejection Messages

The following is a list of CTCI rejection messages. These messages may occur as a result of invalid data entry, lack of data or invalid action taken on the trade.

!REJ - FUNCTION NOT ALLOWED  
!REJ - INVALID MASK  
!REJ - NO SUPERVISORY CALLS ALLOWED FROM THIS TERMINAL  
!REJ - INVALID ENTRY  
!REJ - INVALID ADDRESS  
!REJ - INVALID AUTHORIZATION INDICATOR  
!REJ - INVALID RPID  
!REJ - INVALID DATE  
!REJ - INVALID FORMAT  
!REJ - INVALID FIRM  
!REJ - NOT ALLOWED IN CA PARTITION  
!REJ - ALLOW MUST BE 'Y','N' OR 'S'  
!REJ - INVALID PRICE  
!REJ - INVALID PRICE OVERRIDE  
!REJ - THIS TERMINAL NOT AUTHORIZED FOR UPDATES  
!REJ - MESSAGE NOT WRITTEN  
!REJ - INVALID STATUS  
!REJ - INVALID TIME  
!REJ - INVALID TYPE  
!REJ - RPID REQUIRED  
!REJ - TRACE ENTRY SUSPENDED  
!REJ - INVALID REASON CODE  
!REJ - INVALID SIDE  
!REJ - NOT WITHIN ALLOWABLE TIME  
!REJ - PRICE OUT OF RANGE  
!REJ - PRICE OUT OF OVERRIDE RANGE  
!REJ - TERMINAL NOT AUTHORIZED  
!REJ - INVALID MMID  
!REJ - ALREADY ACTIVE  
!REJ - ALREADY HALTED  
!REJ - NO NEW DATA ENTERED  
!REJ - UPDATE OF FIELD REQUIRED  
!REJ - INVALID CUSIP TYPE MUST BE R OR W  
!REJ - INVALID BOND GRADE MUST BE I OR H  
!REJ - PRIVATE PLACE MUST BE Y  
!REJ - DIS MUST BE N  
!REJ - NO STATISTICS AVAILABLE  
!REJ - DIS MUST BE Y  
!REJ - PORTAL MUST BE N  
!REJ - NOT CUSIP AND SYMBOL  
!REJ - THIS BOND HAS BEEN DELETED  
!REJ - INVALID FUNCTION CODE  
!REJ - CUSIP NUMBER ALREADY EXISTS  
!REJ - INVALID TRADE DATE  
!REJ - ONLY C IS ALLOWED TO CHANGE VALUES  
!REJ - INVALID YIELD  
!REJ - INVALID PERCENT  
!REJ - PRICE REQUIRED

!REJ - PRICE/YIELD REQUIRED  
!REJ - INVALID YIELD SIGN  
!REJ - INVALID BUYER COMMISSION  
!REJ - INVALID DISSEMINATION DELAY TIME  
!REJ - INVALID START TIME  
!REJ - INVALID STOP TIME  
!REJ - INVALID SLD TIME  
!REJ - INVALID PRICE FLAG  
!REJ - INVALID MARKET OPEN TIME  
!REJ - INVALID MARKET CLOSE TIME  
!REJ - INVALID SUPR  
!REJ - INVALID CUSIP NUMBER  
!REJ - INVALID EMC START TIME  
!REJ - INVALID SYMBOL  
!REJ - INVALID COUPON RATE  
!REJ - INVALID BOND DESCRIPTION  
!REJ - INVALID WHEN ISSUE IND.  
!REJ - INVALID EXCHANGE CODE  
!REJ - INVALID CLEARING NUMBER  
!REJ - BOND NOT FOUND  
!REJ - INVALID ACTION CODE  
!REJ - NO RECORDS FOUND  
!REJ - INVALID II  
!REJ - INVALID EI  
!REJ - INVALID CI  
!REJ - INVALID AI  
!REJ - INVALID RI  
!REJ - INVALID MBR  
!REJ - INVALID T-1-CLR#  
!REJ - INVALID VOLUME ENTERED  
!REJ - INVALID HYBRID-ROUTE  
!REJ - END OF RECORDS  
!REJ - INVALID AS-OF  
!REJ - RPID NOT AUTHORIZED  
!REJ - CPID NOT AUTHORIZED  
!REJ - CANNOT CHANGE CUSIP  
!REJ - INVALID RPID GIVE-UP  
!REJ - INVALID CP GIVE-UP  
!REJ - RPID GIVE-UP NOT AUTHORIZED  
!REJ - CPID GIVE-UP NOT AUTHORIZED  
!REJ - MUST ENTER BOND SYMBOL OR CUSIP  
!REJ - NOT A CROSS TRADE  
!REJ - INVALID BOND  
!REJ - YIELD DOES NOT MATCH CALC-YLD  
!REJ - INVALID ACCRUED INTEREST  
!REJ - INVALID SELLER COMMISSION  
!REJ - INVALID TRADE MODIFIER  
!REJ - INVALID P/A  
!REJ - CPID REQUIRED  
!REJ - INVALID CLEARING FLAG  
!REJ - INVALID REPORT FLAG  
!REJ - INVALID SPECIAL TRADE INDICATOR  
!REJ - INVALID SPECIAL TRADE INDICATOR/SPECIAL MEMO  
!REJ - BOND NOT TRACE AUTHORIZED

!REJ - NO CONTROL NUMBER  
!REJ - TRADE ALREADY CANCELED  
!REJ - CANNOT CANCEL 'NO TRADE' TRADE  
!REJ - MM DID NOT ENTER TRADE  
!REJ - INVALID BRANCH SEQUENCE NUMBER  
!REJ - INVALID CONTRA BRANCH SEQUENCE NUMBER  
!REJ - INVALID AS-OF DATE  
!REJ - INVALID REVERSAL FLAG  
!REJ - NOT AN OPEN TRADE  
!REJ - INVALID CPID  
!REJ - CORRECTION MAY NOT CHANGE BOND  
!REJ - SYMBOL ALREADY EXISTS  
!REJ - BOTH CUSIPS HAVE INTERNAL KEYS  
!REJ - CUSIP HAS BEEN CHANGED  
!REJ - INVALID TRADE DATE FOR CHANGED CUSIP  
!REJ - INVALID AGU  
!REJ - CORRECTION MAY NOT CHANGE REVERSAL FLAG  
!REJ - RPID INTRODUCING BROKER SUSPENDED  
!REJ - CPID INTRODUCING BROKER SUSPENDED  
!REJ - EXECUTION TIME GREATER THAN TRADE REPORT TIME  
!REJ - NOT TRADE SUBMITTER  
!REJ - CORRECTION MAY NOT CHANGE AS-OF FLAG  
!REJ - CORRECTION MAY NOT CHANGE CONTRA MPID  
!REJ - CORRECTION MAY NOT CHANGE CONTRA GIVEUP  
!REJ - CORRECTION MAY NOT CHANGE CONTRA CLEARING NUMBER  
!REJ - INVALID TRACE ENTRY - YOUR GIVEUP IS RESPONSIBLE  
!REJ - REGULAR WAY CANNOT BE YIELD BASIS  
!REJ - TEMPORARILY NOT AVAILABLE  
!REJ - CONTROL NUMBER REQUIRED FOR MEMO FIELD